

1ms Column Parallel Vision System and It's Application of High Speed Target Tracking

Y. Nakabo, M. Ishikawa,

H. Toyoda and S. Mizuno

Department of Mathematical
Engineering and Information Physics,
University of Tokyo
7-3-1, Hongo, Bunkyo-Ku,
Tokyo 113-8656, Japan

Central Research Laboratory
Hamamatsu Photonics K.K.
5000, Hirakuchi, Hamakita City,
Shizuoka 434-8601, Japan

nakabo@k2.t.u-tokyo.ac.jp

Abstract

Robot control using a real-time visual feedback has been recently improved (visual servoing.) Conventional vision systems are too slow for these application, because the CCD cameras are restricted to the video frame rate (NTSC 30Hz, PAL 25Hz). To solve this problem, we have developed a 1ms vision system, to provide a far faster frame rate than that of the conventional systems.

Our 1ms vision system has a 128×128 PD array and an all parallel processor array connect to each other in a column parallel architecture, so that the bottleneck of an image transfer has been solved. 1ms visual feedback has been realized in this system, in which the image feature value is extracted in 1ms cycle-time for visual servoing. We have also developed a high speed Active Vision System (AVS)-II, which makes a gaze of vision system to move at high speed.

In this paper, we will provide a detail discussion on our 1ms vision system and its performance through some experiments.

1 Introduction

It is effective to use visual feedback information for systems such as for controlling robots or autonomous land vehicles. In recent years, the study, which realizes visual feedback by a real-time closed loop is popular, these technique is called visual servoing.

But, most of the conventional vision systems are using CCD cameras for image sensing. The transmission speed of an image on these systems has been limited to video rate (NTSC 30Hz, PAL 25Hz). Therefore, the operation speed of the system has been limited to

that of the video rate, even if fast image processing had been carried out. This limitation causes a serious problem when realizing a visual servo control, because it is generally accepted that a servo rate around 1kHz is needed for robot control. Essentially the sampling rate of conventional vision systems is too slow compared to the robot dynamics.

The origin of such a problem lies in the bottleneck of the image transmission. That is to say, high-speed frame rate is difficult to realize using the transmission of the image information, which consists of a lot of pixel datas, through the small number of lines.

On the other hand, Ishikawa et al. have developed a vision chip, and proposed its architecture of S³PE (Simple and Smart Sensory Processing Elements) in which all photo-detectors (PDs) are directly connected to the parallel processing elements (PEs) [1, 2]. These PEs are integrated into one chip so that the bottleneck of the image transmission does not occur and therefore realization of high speed vision systems becomes possible which can provide far faster frame rate than conventional vision systems.

But in this way, a lot of sensors and processing elements must be integrated into one chip, so that the circuit of the processing elements should be compactly designed. Yet this requirement disagrees with the needs to have an ability to carry out various kinds of image processing completed on the PEs. It is reported that 64×64 pixels are the realistically possible limit with satisfying these competitive requests fabricated by the present semiconductor technology [1].

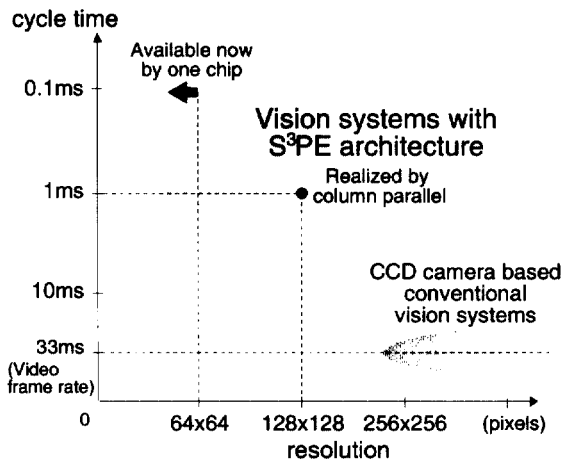

Figure 1 Comparison with conventional image systems

2 Column Parallel Approach

In contrast to these approaches, the system that we developed uses a column type parallel image transfer and it is called Column Parallel Vision (CPV) system. In this system, sensors and processors are *not* integrated into one chip, but implemented on separate chips and boards. The images are transmitted parallel in the columns and using scanning in the rows. Adopting this method, the communication bottleneck has been also solved and, on the other hand, restriction on resolution.

The Figure 1 shows the comparison of each approaches discussed above.

For image processing, the CPV system uses the same S³PE architecture than the one chip integrated vision chip. It has all parallel processing elements for every pixel, so that massively parallel and high speed image processing can be realized. For digitizing the captured image, the system has an 8-bits analog to digital converter array, which is placed in column parallel.

As a result, combining scanning the data in a row and processing it at all parallel, high resolution of 128×128 pixels becomes possible to realize as it is required in robot control applications.

In our previous study, the SPE-256 system has been developed which is recognized to be a pre-step and a scale up model of the vision chip. Using this system, the high-speed target tracking with the active vision system has been developed and the 1ms visual feedback has been realized. Also the system has been applied to various kinds of robot control that much more dynamical than conventional visual servo sys-

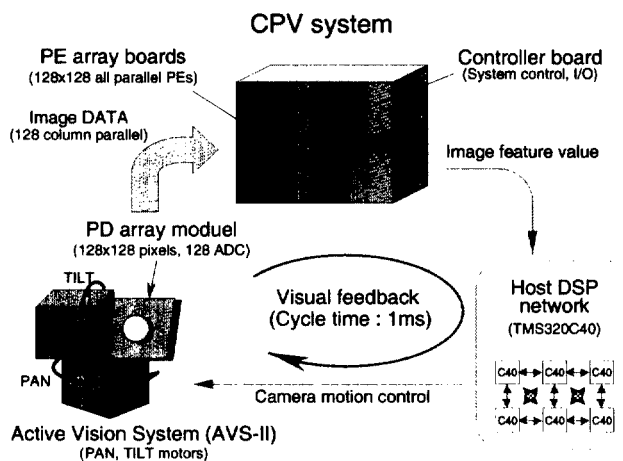

Figure 2 Overview of 1ms vision system

tems [3, 4, 5]. Furthermore, we proposed a novel approach in high-speed image processing and developed various kinds of algorithms utilizing the characteristic of the high frame rate of the vision system [6, 7]. These papers discuss that the high-speed vision system such as the 1ms vision system, which is effective for robot control.

However, the resolution of the SPE-256 system was limited to 16×16 pixels binary images which was remarkably low from integration problems on implementation. It doesn't provide adequate resolution to show the effectiveness of the high-speed vision system. Our new CPV system has 64 times higher resolution, compared to the previous version of our system, an improved 8-bits gray level and all provides in 1ms cycle time.

Also, there was a problem that the response time of the actuator is not enough for high speed visual feedback in the previous version of the active vision system (AVS-I). The recent AVS-II system is designed by considering the match of the vision system and the actuator in the sense a compactness of size and a responsibility.

In the following section, the detail of the 1ms vision system including the CPV system and the AVS-II is described. And then, some experimental results are shown.

3 1ms Vision System

The 1ms vision system consists of the CPV system for the image processing, the active vision system (AVS-II) for the gaze control and a host DSP network for

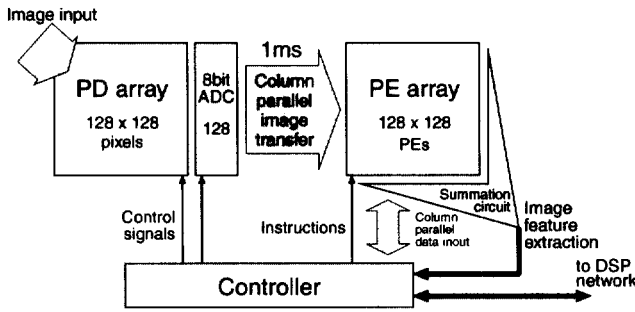

Figure 3 Column Parallel Vision(CPV) system

motion control.

An overview of the whole system is shown in Fig. 2.

3.1 Column Parallel Vision (CPV) System with 128×128 Pixels

In the CPV system, various image processing algorithms applied after the image acquisition which was followed by the extraction of the image feature value as the output to the DSP (Digital Signal Processor) element. This information is used for the visual feedback control.

Inside the CPV system, there are three modules, namely a PD array, a PE array and a controller. The block diagram of the CPV system is shown in Fig. 3. At the following paragraph, details in each systems are described.

3.1.1 PD Array

The PD array consists of photo-detectors and an AD converter array which are integrated into one chip. The resolution of the PD array is 128×128 pixel. AD converter array is in 128 lines column parallel and have an 8-bits gray scale resolution. The output image data from a selected row in PD array is transmitted to the PE array in 128 lines column parallel. As a result, all the pixel data of each frame can be read in around 1 ms.

3.1.2 PE Array

The image processing part consists of 128×128 parallel PEs array that realizes a totally parallel processing in each pixel of the image. The inner structure of the PEs is based on the S³PE architecture [2], which adopts a SIMD type program control, 4-neighbor connection, a bit serial ALU, 24-bits local memory and memory mapped I/Os. These all are to satisfy the needs of

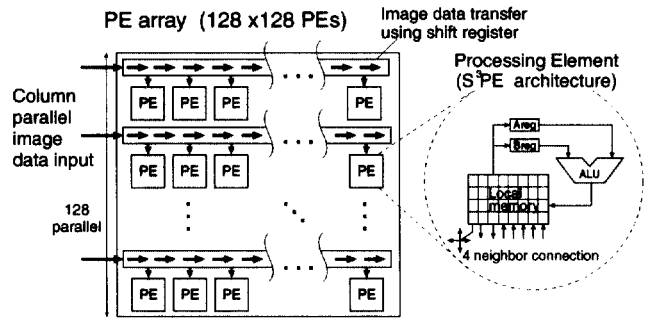

Figure 4 S³PE architecture with column parallel data transfer

compactness and functionality. The controller sends the instructions for the PEs. Full descriptions of the controller are written in the next paragraph.

The datas of pixels from PDs are transferred to the corresponding PEs by using shift registers implemented in the CPV system. Using this interface, the sensor datas are forwarded one bye one from selected column of the PD array, and are taken in the PEs with corresponding column.

For the implementation of this massively parallel PE array, 128 chips (XILINX XC4044XL) of FPGA (Field Programmable Gate Array) are used. Every chip has 16×8 PEs and all the chips are loaded on eight sheets of circuit boards. 1 instruction of the system is executed within 330ns at present.

The figure 4 shows the architecture of S³PE with column parallel data transfer used in the PE array.

3.1.3 Controller

In general, when constructing a parallel processing system, the role of controller is important, which regulates the operation of the whole system and carries an interface with outer system without the bottleneck. An architecture of the controller is shown in Fig.5.

Corresponding to the purpose of the CPV system given at the beginning of this section, the functions realized in this controller are described as follows.

- Extracting and calculating image feature values :
Extracting and calculating image feature value as a result of processing in the PE array. An exclusive circuit makes it possible to summarize all outputs of PEs without any delay.
- The interface of data in/out with the PE array :
Carrying out 128-line parallel data input/output with the PE array.

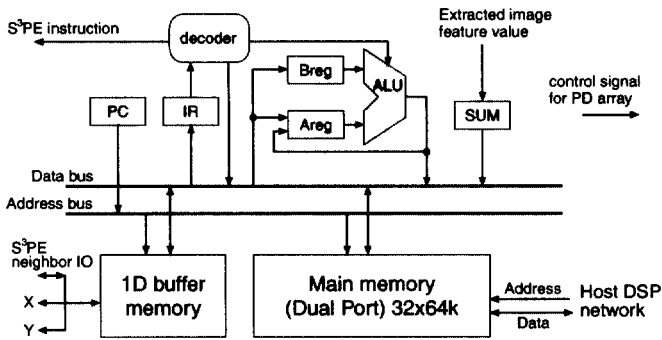

Figure 5 Architecture of Controller

- The SIMD control of the S³PE :
Sending instructions to the PE array and regulating SIMD control.
- The control of the system by the user program :
Being all operation of the system controlled by the user program which is downloaded to the main memory.
- The interface with the outer system :
Caring out data input/output without the bottleneck with host DSP system using the sharing memory method.
- Managing the synchronization of the total system :
Managing the synchronization of all modules in the CPV system.

An implementation of the controller is also realized by FPGA. It uses two chips (XILINX XC4044XL) loaded on one board.

As a result, the CPV system satisfies the goal of the cycle time of 1ms, because a series of processing and a flow of information for the visual feedback control are ideally implemented without the bottleneck.

3.2 Active Vision System (AVS)-II

The AVS-II is an actuator part of the 1ms vision system to make a gaze move at high speed. The PD array is loaded on the mobile platform which has two degrees of freedom; pan and tilt; and each axes have the Σ -II AC servo motor (100W) made by Yaskawa electric corporation. The motors are used by direct drive and without any gears which allows it to remove the disturbance of the effects of the friction. High power and compact size are realized together with the fast response time compared to the previous version of our active vision system [3, 6].

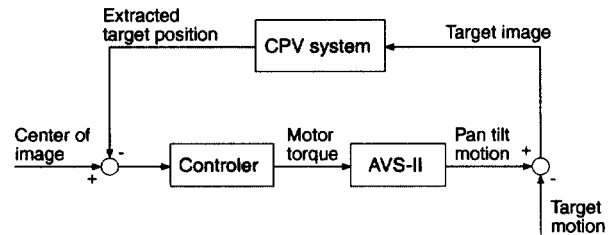

Figure 6 Block diagram of AVS-II control

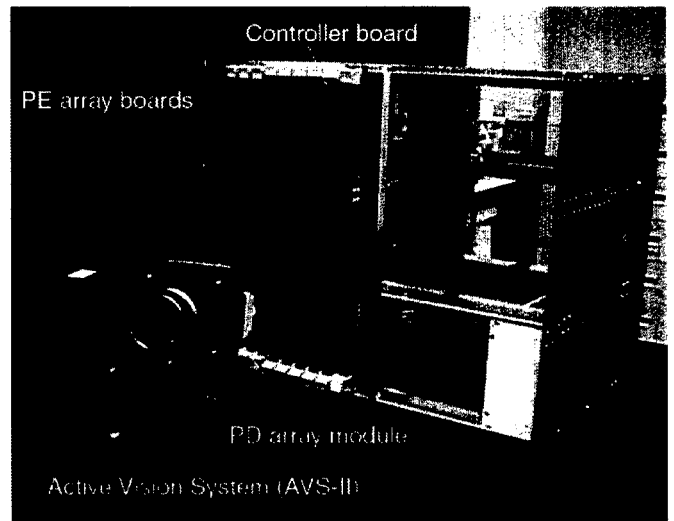

Figure 7 CPV system with AVS-II

The control of the motion are carried out in the host DSP network which used parallel processing DSPs (TMS320C40 by TI). Using the DSP network enables 1ms cycle time without bottleneck dispersing load of the processing and I/Os [5].

The block diagram of the control of the AVS-II is shown in Fig.6. A real-time visual servo control by the method of torque control is constructed.

The photograph of the CPV system and the AVS-II is shown in Fig.7.

4 Experimental results

4.1 High Speed Image Processing

At first, several kinds of generally used image processing had been carried out to confirm the performance of the CPV system.

In the experiments, 8-bits digitized images are continuously obtained at PD array. Image processing is applied at every frame cycle carried out by parallel

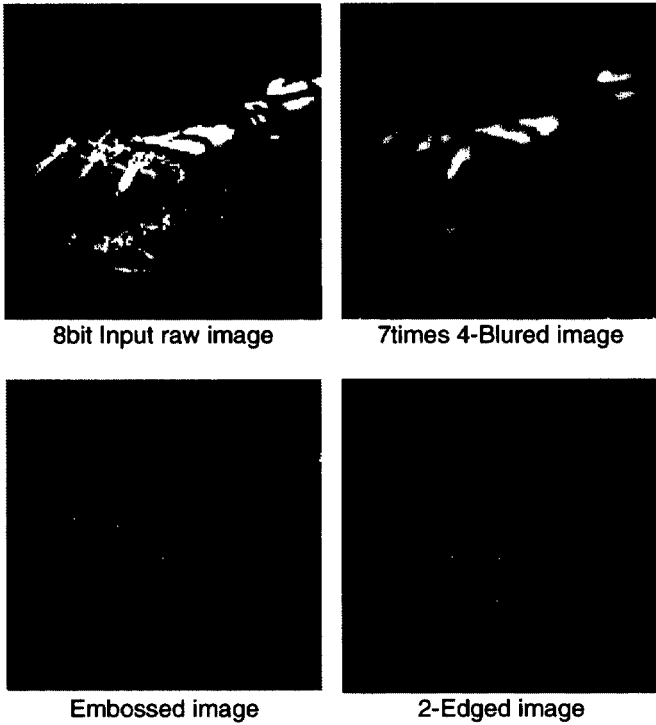

Figure 8 Image processing carried out in CPV system

image processing	steps	time
8-bits data input	8	26.6 μ s
2-neighbor blur	58	19.3 μ s
7-neighbor blur	406	135.3 μ s
2-neighbor emboss	59	19.6 μ s
2-neighbor edge	59	19.6 μ s

Table 1 Image processing time in CPV system

processing on the PE array. To make it easy to verify the results of the image processing, the frame rate is temporary kept down to around 50 fps to avoid effect of the noise of the sensor .

The image processing executed in the experiments is 2-neighbor blur, 7 times 4-neighbor blur, 2-neighbor embossing and 2-neighbor edge detection. The instruction steps and the processing time are shown in Tab.1. The dumped images of each results are shown in Fig.8.

It is shown that the results of each image processing are obtained correctly. Also, it should be emphasized that the numbers of the steps executed through the image processing are remarkably small owing to an all parallel processing at PE array.

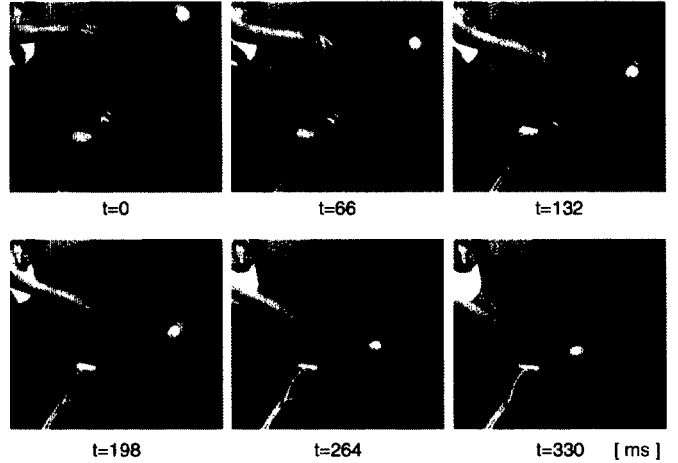

Figure 9 Photo strip of target tracking

processing contents	steps	time
3-bits data input	3	1.0 μ s
filtering	41	13.6 μ s
self windowing	6	2.0 μ s
extracting centroid	126	42.0 μ s
total	176	58.6 μ s

Table 2 Processing time on target tracking

4.2 Tracking Irregular Motion of Target

The next experiments are carried out using an active vision actuator to verify the performance of the system as the visual servo system by applying to target tracking.

Because the high speed of the system is important in this experiment, realizing the 1ms cycle time in visual feedback is set to be the goal. In practice, 3-bits images are used and a 1kHz frame rate is realized which is adequate for target tracking application.

As the image processing, filtering, thresholding, self windowing[6] for target recognition and extracting centroid of the target pattern are executed on every frame.

The instruction steps and the processing time are shown in Tab.2.

Figure 9 shows the result of the target tracking. The active vision experiment keeps tracking the white ball as the target, as shown in the photos. The experiment proved that the system is sufficiently tracking even if the target moves fast and irregularly.

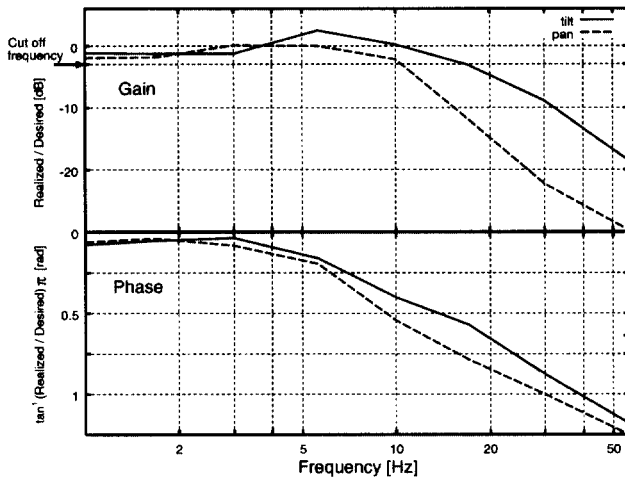

Figure 10 Frequency Response of Target Tracking

4.3 Frequency Response of Target Tracking

The frequency responses of each axes of the system are measured during the target tracking.

The target in this experiment is fixed to the base of the system and the goal position given in the image plane which is in a different frequency of sinusoid wave. From the trajectory and the goal position of the tracking motion, the gain and the phase shift are calculated. For the control law of the motion, phase improving method is used.

The result is shown in Fig.10. It yields that the actuators of the both axes, tilt and pan, can follow the violent change of the goal position at more than 10Hz of the cutoff frequency.

From this result, it is clear that a very high response characteristic has been proposed by our visual servo system, much higher than that of the conventional systems.

5 Conclusion

In this paper, several vision system approaches are discussed, such as the conventional vision systems using CCD cameras restricted by the video frame rate, then the one chip directed vision chip approach and its scale up model that have already been developed at present. Compared with these approaches, the CPV system, combining a column parallel image data transfer and an all parallel processing architecture based on an S³PE architecture, have been realized, and provides higher resolution with 1ms cycle time required for the

applications of visual servoing.

From the detail of the system described in the earlier part of the paper, it is possible to say that the system has sufficient functions for the required tasks and applications. And from the experimental results described in the paper, the high performance of the system is clearly shown in total, including the CPV system and the AVS-II.

In progress, this system will be applied for a wide field of the applications such as a dynamical robot control or a real-time human interface, and also for developing image processing algorithms using high speed vision system.

References

- [1] M. Ishikawa, K. Ogawa, T. Komuro, and I. Ishii. A cmos vision chip with simd processing element array for 1ms image processing. In *Dig. Tech. Papers of 1999 IEEE Int. Solid-State Circuits Conf. (ISSCC'99)*, pages 206–207, 1999.
- [2] T. Komuro, I. Ishii, and M. Ishikawa. Vision chip architecture using general-purpose processing elements for 1ms vision system. In *Proc. IEEE Int. Work. on Computer Architecture for Machine Perception*, pages 276–279, 1997.
- [3] Y. Nakabo, I. Ishii, and M. Ishikawa. High speed target tracking using 1ms visual feedback system. In *Video Proc. IEEE Int. Conf. on Robotics and Automation*, 1996.
- [4] Y. Nakabo and M. Ishikawa. Visual impedance using 1ms visual feedback system. In *Proc. IEEE Int. Conf. on Robotics and Automation*, pages 2333–2338, 1998.
- [5] A. Namiki, Y. Nakabo, I. Ishii, and M. Ishikawa. High speed grasping using visual and force feedback. In *Proc. IEEE Int. Conf. on Robotics and Automation*, pages 3195–3200, 1999.
- [6] I. Ishii, Y. Nakabo, and M. Ishikawa. Target tracking algorithm for 1ms visual feedback system using massively parallel processing vision. In *Proc. IEEE Int. Conf. on Robotics and Automation*, pages 2309–2314, 1996.
- [7] I. Ishii and M. Ishikawa. Self windowing for high speed vision. In *Proc. IEEE Int. Conf. on Robotics and Automation*, pages 1916–1921, 1999.